

Kelvion R/N/GF Flatbed Condenser and Gas cooler

IMPROVED ENERGY EFFICIENCY, QUIETER OPERATION



YOUR BENEFITS

- ▶ The Flatbed range has been developed specifically to reflect the latest market requirements. Reduced footprint, lower noise level, improved capacity density and the greatest flexibility through configurable options to suit all requirements. Coil configurations of 5, 8, 10, and 12mm are available in the variety of length, width and height variants, ensuring the most efficient solution is always offered across all potential applications.
- ▶ The special plate work form developed by Kelvion allows for supporting coils up to 12m in length, giving significant strength and forms an integral part of the heat exchanger support structure.
- ▶ A comprehensive collection of fan sets are available from various premium manufacturers. This ensures that the best fan is always selected and balanced against the model and application variant. High energy efficiency, low noise and flexible control options all ensure the best possible solution is offered.
- ▶ Eurovent certify-all: independent certification for thermal performance, power consumption, sound data and unit air volumes for standard products under scheme limits.
- ▶ CE Marked, PED compliant and UL Certified: Kelvion products can be supplied from SEP up to category IV

CAPACITY RANGE

HFO/HFC 24 kW - 1409 kW

$t_{L1}=25^{\circ}\text{C} \mid t_o=40^{\circ}\text{C} \mid \text{DT}=15\text{K} \text{ [SC1]}$



11 kW - 1330 kW

$t_{L1}=25^{\circ}\text{C} \mid t_o=40^{\circ}\text{C} \mid \text{DT}=15\text{K} \text{ [SC1]}$



30.6 kW - 1423.6 kW

$t_{L1}=30^{\circ}\text{C} \mid P_{R1}=90 \text{ bar} \mid t_{R1}=110^{\circ}\text{C} \mid t_{R2}=35^{\circ}\text{C} \text{ [SC20]}$



DIMENSIONS

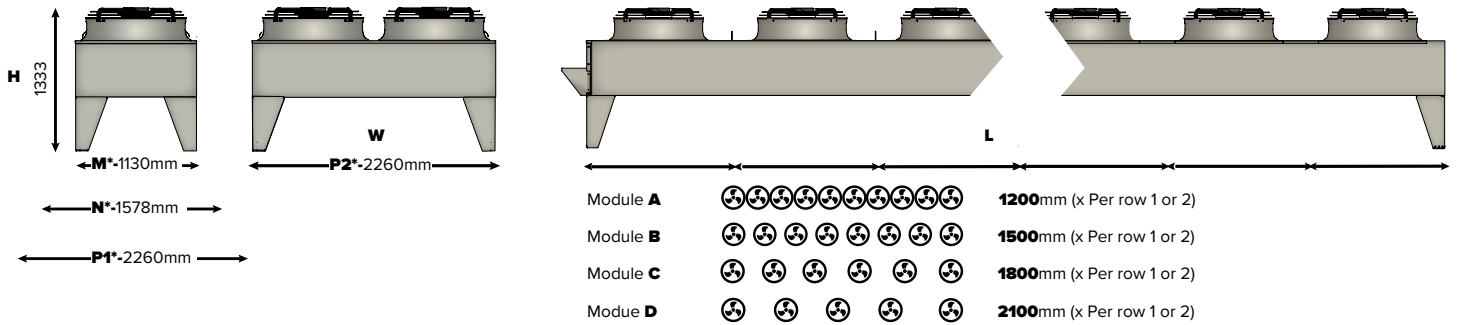

FANS

▶ AC Normal	Ø 800 mm	▶ Min IP 54
▶ AC High power	Ø 810 mm	▶ 6, 8, 12 Pole and EC
▶ EC Standard	Ø 900 mm	▶ 1 & 3 phase
▶ EC High power	Ø 910 mm	▶ 50/60 Hz
▶ EC Low power		▶ 1 - 20 fans

HEAT EXCHANGE

▶ Fin Type: Condensers: L, T, F Gas Coolers: F, T, G
▶ Standard Fin spacing: [mm] L = 2.1 T = 2.3 F = 2.1 G = 2.1
▶ Fin material: Cu, Al, Av, AlMg, Bg
▶ Tube Diameter: [mm] L = 9.5 T = 12 F = 5 G = 8
▶ Tube material: All types: Cu, St/St: T fin only

CONTROLS OPTIONS

OPTION	DESCRIPTION
Kelvion SmartControl	Connected to the Kelvion cloud to give live operational data
Unwired	Installer wires directly to fan terminal boxes
Junction Box	Single or twin according to unit model
Staged Control (AC Fan sets)	Motor switchgear with or without controller.
Speed Control	EC, inverter or triac
Modbus	Options for control communication of fan and control

VARIANTS & ACCESSORIES

▶ Legs Extended & Hinged fan plate
▶ Control Box & Isolators
▶ Sub cooling
▶ Multi sections
▶ Adiabatic System
▶ Packing & Stacking
▶ Alternative Fin Material & Special Paint
▶ Mounted Receivers and Frames
▶ Customised Housing

OPERATING ENVIRONMENT GUIDANCE

NOTE

APPLICATION ATMOSPHERE	TUBE MATERIAL	FIN MATERIAL
Commercial Application	Cu or St/St	Al, AV, AlMg, Cu, Bg
Industrial Application	Cu or St/St (NH3 must be St/St)	Al, AV, AlMg, Cu, Bg
Within 20 miles of the Sea	Cu	Cu, Bg, AlMg
Waste Disposal	Cu	Al, AV, AlMg, Cu, Bg

NOTE: The Tube material will suit fin Material

Selection and Pricing on all products can be performed on the **Selection Software** which can be downloaded from our website www.kelvion.com