

## Kelvion LF Dry air cooler

# PUSHING FORWARD WITH INNOVATIVE IDEAS







## YOUR BENEFITS

- ▶ Using the latest innovative design: the range can incorporate 9.5, 12, or 15.9mm tube diameters. Each optimized for specific operating conditions, the Kelvion selection software will balance application requirements to offer best possible product.
- ▶ The special plate work form developed by Kelvion allows for supporting coils up to 12m in length, giving significant strength and forms an integral part of the heat exchanger support structure.
- ▶ A comprehensive collection of fan sets are available from various premium manufacturers. This ensures that the best fan is always selected and balanced against the model and application variant. High energy efficiency, low noise and flexible control options all ensure the best possible solution is offered.
- ▶ Eurovent certify-all: independent certification for thermal performance, power consumption, sound data and unit air volumes for standard products under scheme limits.
- ▶ CE Marked, PED compliant and UL Certified: Kelvion products can be supplied from SEP up to category IV

## CAPACITY RANGE

**H<sub>2</sub>O 21 kW - 1290 kW**  
 $t_{A1}=25^{\circ}\text{C} \mid t_{L1}=40^{\circ}\text{C} \mid t_{L2}=35^{\circ}\text{C}$

---

# DIMENSIONS

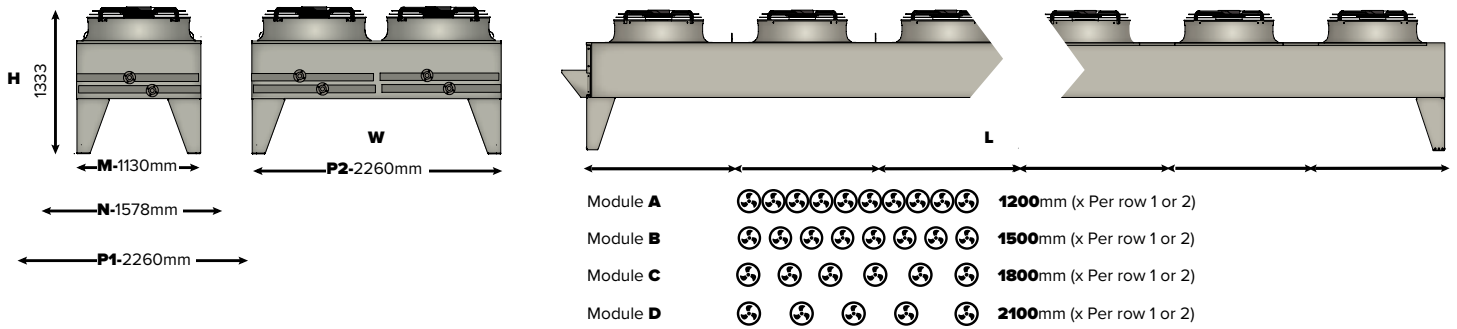

# FANS

▶ AC Normal	Ø 800 mm	▶ Min IP 54
▶ AC High power	Ø 810 mm	▶ 6, 8, 12 Pole and EC
▶ EC Standard	Ø 900 mm	▶ 1 & 3 phase
▶ EC High power	Ø 910 mm	▶ 50/60 Hz
▶ EC Low power		▶ 1 - 20 fans

# HEAT EXCHANGE

▶ Fin Type: L, T, K
▶ Standard Fin spacing: [in mm] L = 2.1   T = 2.3   K = 2.3
▶ Fin material: Cu, Al, Av, AlMg, Bg
▶ Tube Diameter: [in mm] L = 9.5   T = 12   K = 15.9
▶ Tube material: Cu, St

# CONTROLS OPTIONS

OPTION	DESCRIPTION
Kelvion SmartControl	Connected to the Kelvion cloud to give live operational data
Unwired	Installer wires directly to fan terminal boxes
Junction Box	Single or twin according to unit model
Staged Control (AC Fan sets)	Motor switchgear with or without controller.
Speed Control	EC, inverter or triac
Modbus	Options for control communication of fan and control

# VARIANTS & ACCESSORIES

▶ Legs Extended & Hinged fan plate
▶ Control Box & Isolators
▶ Sub cooling
▶ Multi sections
▶ Adiabatic System
▶ Packing & Stacking
▶ Alternative Fin Material & Special Paint
▶ Mounted Receivers and Frames
▶ Customised Housing

# OPERATING ENVIRONMENT GUIDANCE

# NOTE

APPLICATION ATMOSPHERE	TUBE MATERIAL	FIN MATERIAL
Commercial Application	Cu or St/St	Al, AV, AlMg, Cu, Bg
Industrial Application	Cu or St/St (NH3 must be St/St)	Al, AV, AlMg, Cu, Bg
Within 20 miles of the Sea	Cu	Cu, Bg, AlMg
Waste Disposal	Cu	Al, AV, AlMg, Cu, Bg

**NOTE:** The Tube material will suit fin Material

Selection and Pricing on all products can be performed on the **Selection Software** which can be downloaded from our website [www.kelvion.com](http://www.kelvion.com)