

Kelvion



Product Line: Shell & Tube Double Safety

SAFE **BY DESIGN**



Kelvion



EXPERTS IN HEAT EXCHANGE – SINCE 1920

Welcome to Kelvion! Where Heat Exchange is our Business. We are one of the leading global manufacturers of heat exchangers and have been providing solutions for almost every industrial application imaginable since the 1920s, specializing in customized solutions suitable for extreme environmental conditions - as of 2015 under the name of Kelvion.

With one of the most extensive selections of heat exchangers in the world, we are a well-known partner in many industries, including transportation, energy, oil and gas, chemical, marine as well as food and beverage, data center and the HVAC and refrigeration technology sector. Our products include Compact Fin Heat Exchangers, Plate Heat Exchangers, Single Tube Heat Exchangers, Transformer Cooling Systems, Cooling Towers and Shell & Tube Heat Exchangers.

Our many years of experience and in-depth expertise have made us specialists in this field. Our heat exchangers are designed specifically to meet the needs of the respective machine or equipment system, ensuring outstanding energy efficiency and reliability in any market segment. This gives our customers a cutting-edge over their competitors while also reducing operating costs over the long term.

As your heat exchange partner, we understand that outstanding and reliable after-sales services are critical for you, our customer, and we work alongside with you in close partnership supporting you throughout the full life cycle of your plant and equipment to ensure lasting business success.

Kelvion – Experts in Heat Exchange.

KELVION – A TRIBUTE TO LORD KELVIN (1824 - 1907)



Lord Kelvin formulated the laws of thermodynamics and absolute units of temperature are stated in kelvin, in his honor.

OUR LOGO – INSPIRED FROM THE SCHEMATIC FOR HEAT EXCHANGER

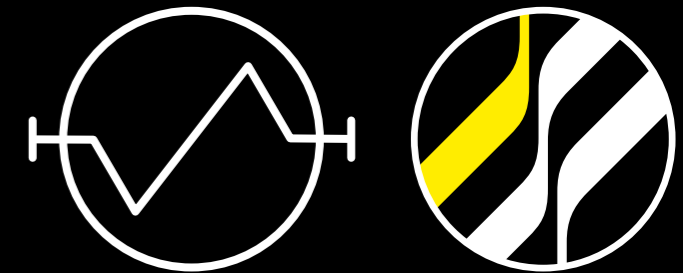

67 BRANCHES AND SALES PARTNERS WORLDWIDE

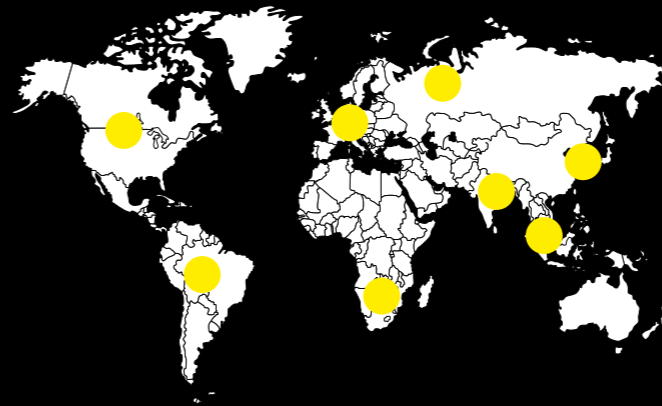

5,000 EMPLOYEES WORLDWIDE

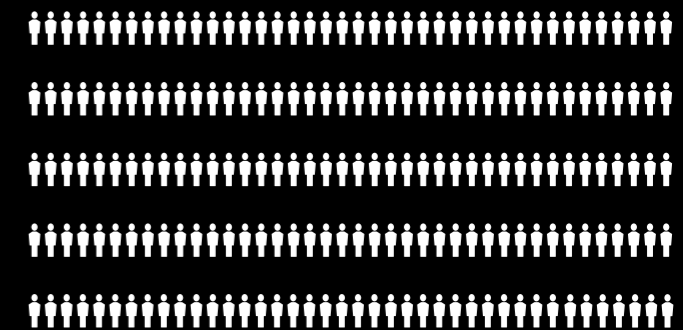

YOUR MARKETS ARE OUR MARKETS

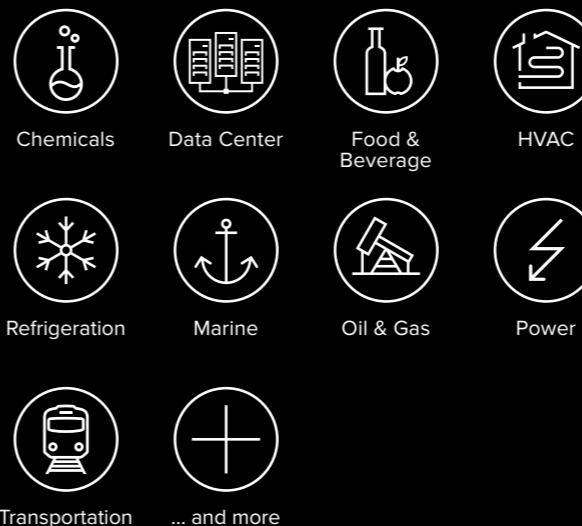

KELVION HAS A LONG HISTORY



Process safety increased

CUTTING-EDGE TECHNOLOGY FOR OPERATIONAL SAFETY AND RELIABILITY



Double tube safety heat exchangers play an important role in applications where preventing media mixing in the event of a leak is paramount. They are widely used and accepted as standard in the chemical industry, power, heavy and light industry, oil & gas, marine, transportation, refrigeration and food & beverage sectors.

Kelvion has a long track record in developing ground-breaking technologies always aiming to reach the highest levels of safety, environmental protection and cost-efficient operation. Our expert engineers are fully trained to provide you with the best-in-class solutions tailored to your specific requirements. As industries face ever stricter regulations for safeguarding requirements of environment and water supply, double tube safety heat exchangers are the technology of choice.



KEY BENEFITS AT A GLANCE

- ▶ Safe media separation and leak monitoring
- ▶ High availability of production plants
- ▶ Minimal energy requirement
- ▶ Safe and cost-efficient operation
- ▶ More economical and environmental compliant
- ▶ Simplifies processes
- ▶ Process efficiency

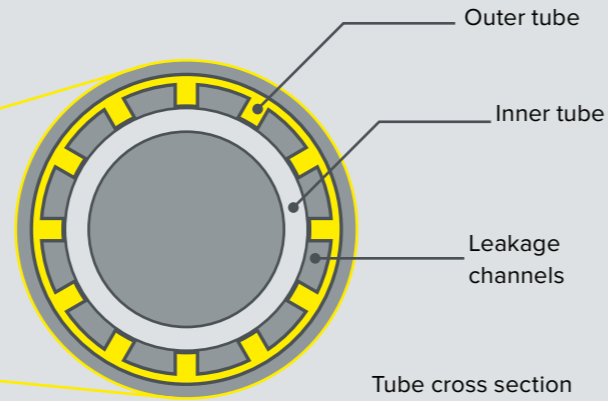
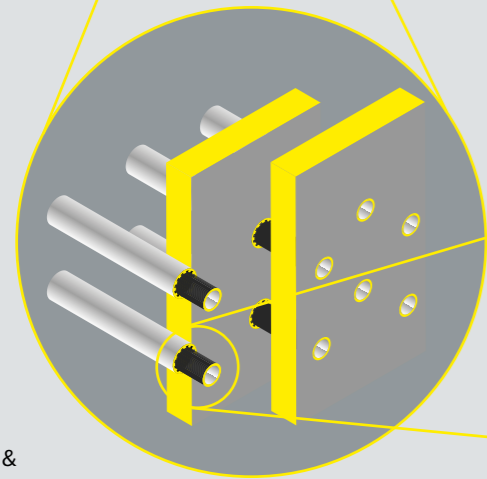
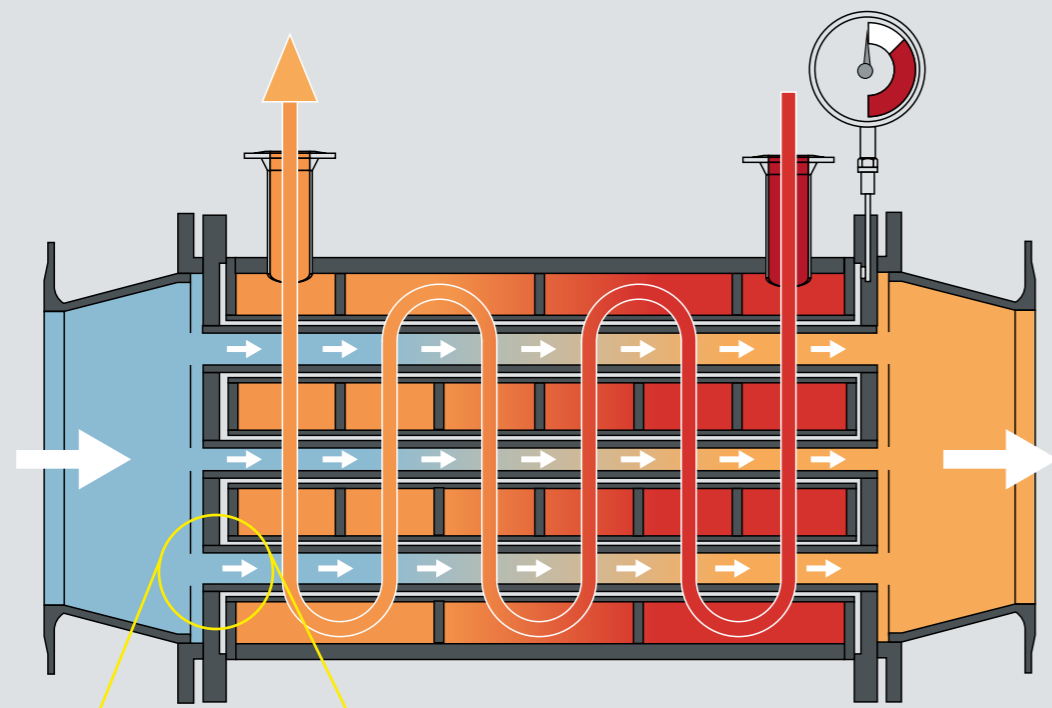

Double tubes & double tube sheets

LEAKAGE DETECTION SYSTEM

We offer a range of devices in our portfolio for the leakage detection system. These include:

- ▶ Level indicators
- ▶ Capacitive indicators
- ▶ Pressure indicators

These can be combined with display units and further armatures. In addition, we can supply air dehumidifiers and diaphragm tanks for isolation and pressure compensation in the leak chamber, if required.

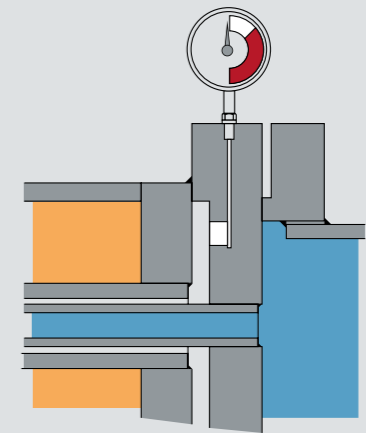

Regular operation

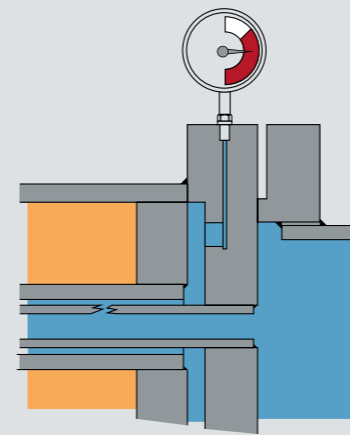

Alarm 1
Inner tube leakage

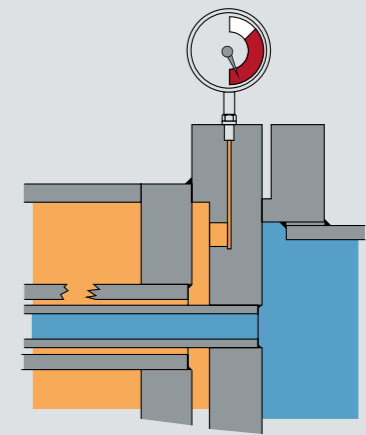

Alarm 2
Outer tube leakage

DOUBLE TUBES FUNCTION AND DESIGN

Unlike a standard shell & tube heat exchanger with a single wall design, the tubes in double tube safety models have two walls, consisting of an inner and outer tube. They also have two tube sheets at each end.

If a tube wall is damaged, the product flows through leakage channels arranged between the double tubes into a leakage collection space and triggers an alarm in the leak detection device. Because the second tube wall remains undamaged, the media are kept separate.

This means that the plant operator can continue to run the heat exchanger until the next maintenance, avoiding costly unplanned downtimes, as well as contamination of your process and its equipment.

SAFETY FIRST WITH DOUBLE TUBES

Kelvion double tube safety heat exchangers are available in different materials or their combinations, depending on application and media. The inner tube is normally plain, while the outer tube has a carved fin profile on the inside. This ensures the contact between the two tubes for optimum heat transfer. It also generates channels between the tubes for leaking media, which are then registered by the leak detector. Depending on the application and different media properties, the outer surface of the outer tube can be executed in a plain or low-fin design.

Advantages of Shell & Tube Double Safety

SAFE SEPARATION OF MEDIA IN ONE HEAT EXCHANGER



The tube within a tube feature of the double tube safety heat exchangers offers significant advantages over its single tube counterpart.

Even if single tube heat exchangers are highly efficient and comply with strict quality controls, there is the risk of product mixing in the event of a tube leakage. To offset such risk, plants would need to use at least two bigger exchangers combined in an intermediate circuit to ensure media separation. This configuration also requires regulating systems as well as other accessories and has a high energy demand.

Double tube safety heat exchangers enable safe separation of two media in only one heat exchanger. No intermediate circuits are required and any leaks are detected immediately, with thank to our online monitoring system and without any risk to the overall process, products, machines and the environment. For customers this means that their operations can be carried out continuously, reliably and cost effectively.

Kelvion's Shell & Tube Double Safety technology is more economical to run and uses less energy. Our systems also help you to comply with strict environmental regulations.

Advantages of Shell & Tube Double Safety

SINGLE TUBE VS DOUBLE TUBE

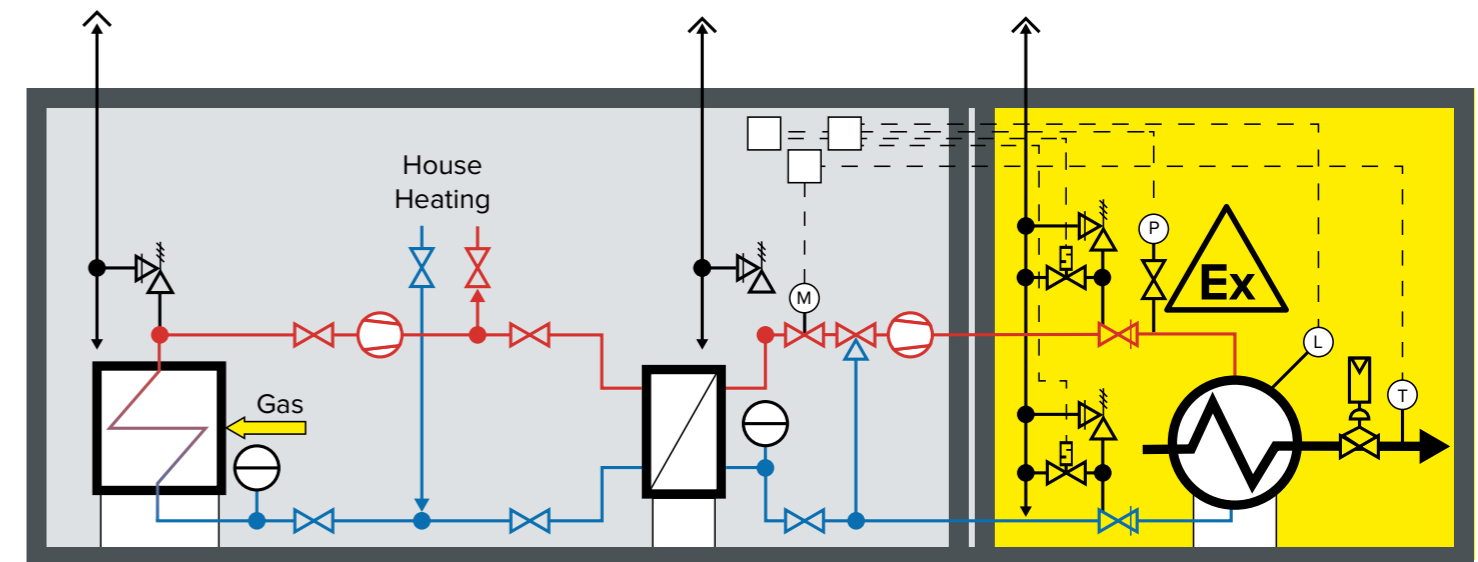

Natural gas preheating system without double tube safety heat exchanger

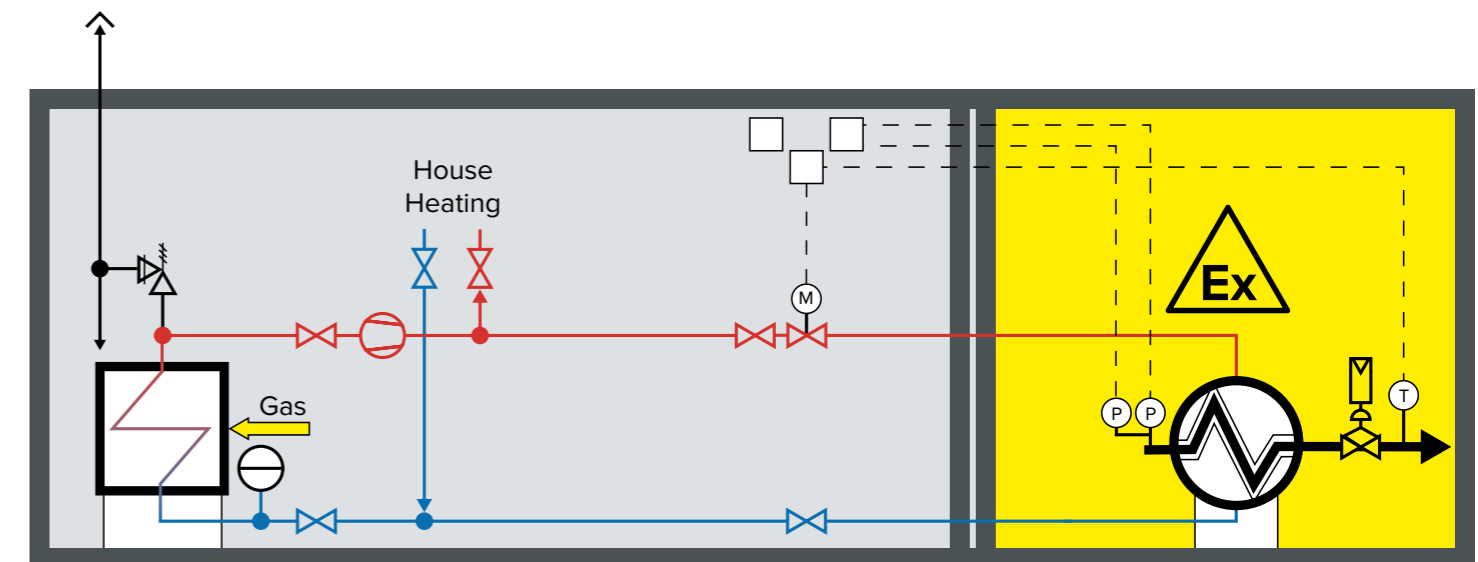

Natural gas preheating system with Kelvion Shell & Tube Double Safety

High availability of production plants

In the event of a leak the detection system will trigger an alarm. The added protection of the second tube avoids having to shut down critical processes and gives customers peace of mind. Repairs can be carried out during the next maintenance cycle.

Leaks of hazardous substances are not only a threat for health and the environment. They can also have a negative impact on a company's finances and tarnish its reputation.

Our products help to increase the reliability of processes and support consistent high product quality.

Product line overview

SHELL & TUBE DOUBLE SAFETY

Kelvion is a market leader in double tube safety technology, with more than 40 years' experience in supplying pioneering solutions that are at the forefront of industry standards. Our product line Shell & Tube Double Safety comprises standard, advanced and customized models, all designed

and manufactured in close cooperation with our customers to meet the demands of their applications. We are continuously adapting our range to suit changing market requirements, as well as developing new products.

STANDARD

The standardized and cost efficient solution



ADVANCED

Welded shell design for demanding requirements



CUSTOMIZED

Sustainable solutions for special applications



Typical Media

- ▶ Water
- ▶ Steam
- ▶ Oil
- ▶ Refrigerants and glycol
- ▶ Natural gas
- ▶ Solvents
- ▶ Chemical and toxic media

Typical Applications

- ▶ Machine Cooling
- ▶ Thermal oil heating/cooling
- ▶ Natural gas heating and cooling
- ▶ LNG treatment
- ▶ Chlorine liquefaction
- ▶ Ammonia evaporation
- ▶ Polysilicon treatment

Design Data

- Pressure
- ▶ up to 100 bar, higher on request (shell side)
 - ▶ up to 320 bar, higher on request (tube side)
- Temperature
- ▶ -200 to 550°C (tube side and shell side)

Materials

- ▶ Carbon steel
- ▶ Stainless steel
- ▶ Copper
- ▶ Non-ferrous metals (CuNi)
- ▶ Titanium
- ▶ Hastelloy
- ▶ Super Duplex

Classification societies and institutions

- ▶ Det Norske Veritas - Germanischer Lloyd (DNV-GL)
- ▶ American Bureau of Shipping (ABS)
- ▶ Lloyds Register of Shipping (LRS)
- ▶ Bureau Veritas (BV)
- ▶ Registro Italiano Navale (RINA)
- ▶ Russian Maritime Register of Shipping (RS)
- ▶ China Classification Society (CCS)
- ▶ TÜV

Design Codes

- ▶ AD 2000
- ▶ EN 13445
- ▶ ASME
- ▶ TEMA

Regulations and certifications

- ▶ PED
- ▶ ASME Code Stamp (U)
- ▶ KTA - Certificate
- ▶ EAC - Certificate (TR-TS)
- ▶ SELO (China)
- ▶ CRN (Canada)
- ▶ DIN 2303 Q2
- ▶ Euro Chlor
- ▶ DVGW

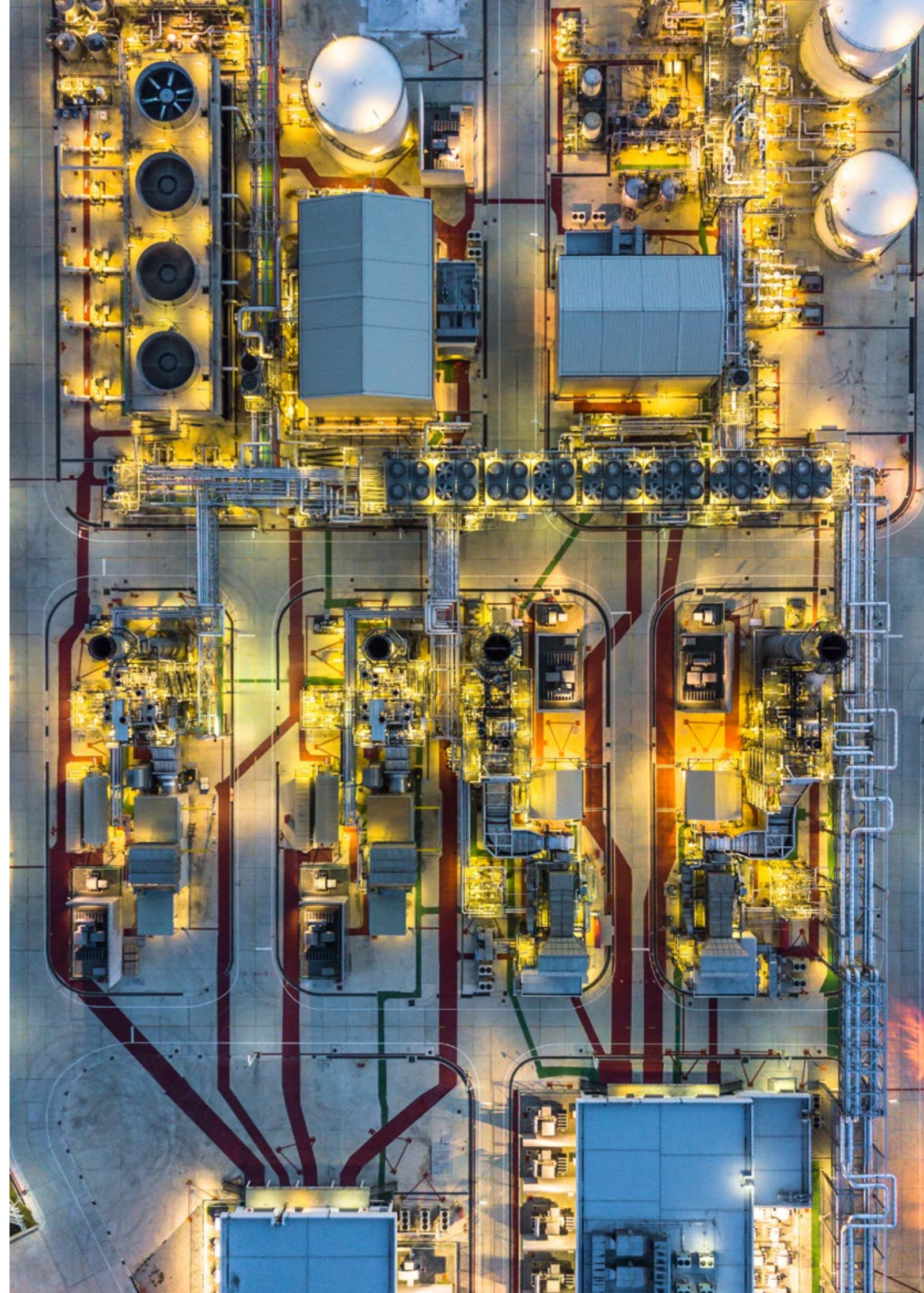

Shell & Tube Double Safety– Standard

THE STANDARDIZED AND COST EFFICIENT SOLUTION



The standardized Shell & Tube Double Safety is the cost-efficient solution for low to medium temperatures and pressures. Its modular shell design – in accordance with AD 2000 – is available in diameters ranging from 130 mm up to 280 mm and is suitable for clean water, open water and seawater applications.

The tube bundles for this model range between a length of 250 mm and 3600 mm. Outer tubes are generally made in copper, with a plain or low-fin design. But where copper is incompatible with the shell side medium, we will use carbon steel. The choice of material for the inner tube can be made independently and is typically copper-nickel, carbon steel or stainless steel. This type of heat exchanger is suitable mostly for machine cooling purposes.

Shell & Tube Double Safety – Advanced

WELDED SHELL DESIGN FOR DEMANDING REQUIREMENTS



If the demand for your application exceeds the maximum size, performance or construction features of the standard model, our advanced solution is the perfect choice. It can handle temperatures of -29 °C to 400 °C and pressures up to 60 bar(g) shell side and up to 40 bar(g) tube side.

Based on a welded shell design, our advanced series can be manufactured in a wide range of materials and configurations. The inner tubes are plain while the outer tubes are available as plain or low-fin to increase the outer surface.

The outer tubes are copper for low-fin or carbon steel for plain types, while the inner tube choices include copper-nickel 90/10, copper-nickel 70/30, stainless steel and carbon steel. We also offer an optional inside phenolic coating.

The advanced series can be supplied as single units or with changeover valves and pipes in a heat exchanger set. This series is typically suited to machine cooling, thermal oil heating/ cooling and to combined heat and power systems.

Shell & Tube Double Safety – Customized

SUSTAINABLE SOLUTIONS FOR SPECIAL APPLICATIONS



For applications operating either at a higher temperature and pressure range or for the use of safety critical media we recommend a customized solution that is tailored to these requests.

We can supply fluid to fluid, gas to gas and gas to fluid heat exchangers, in the function as condensers, evaporators and even simultaneous phase changes on both sides of the unit. The tube bundles in customized models can have a length of 500 mm to 8,000 mm and can withstand temperatures from -200 to 550°C.

Outer tubes are usually manufactured in carbon steel, stainless steel, copper-nickel, Hastelloy or Super Duplex steel.

The same materials are used for the inner tubes, as well as additionally titanium. The design pressure range is 0 to 100 bar on the shell side and 0 to 320 bar on the tube side. Other pressures will be available on request.

We can deliver our Shell & Tube Double Safety as a fully pre-installed skid system, together with armatures, measurement equipment and pumps – a comprehensive 'plug in and play' solution.

Even solutions are possible where also the whole shell and additional pipework is manufactured in double wall design.













Shell & Tube Double Safety – Applications, industries and product examples

HARD-WORKING SOLUTIONS FOR THE TOUGHEST PROCESSES

INDUSTRIES

			
OIL & GAS	CHEMICALS	ENERGY	HEAVY & LIGHT INDUSTRY
			
MARINE	REFRIGERATION	TRANSPORTATION	FOOD & BEVERAGE

Where processes have to be perfectly controlled and conform to the strictest safety standards and environmental regulations, the Kelvion Shell & Tube Double Safety is the perfect partner. It can be relied on to operate in the harshest conditions, while helping to minimize process costs and optimize energy efficiency.

Our Shell & Tube Double Safety can be found in many key industries: energy & power, oil & gas, chemicals, marine, heavy & light industries, transportation, refrigeration and food & beverage.

The following examples demonstrate their superior performance in machine cooling systems, water heating, polysilicon production, chlorine liquefaction and in the field of natural gas treatment.

Shell & Tube Double Safety – Advanced

MACHINE OIL COOLING



Shell & Tube Double Safety – Advanced

WATER HEATER IN COMBINED HEAT AND POWER SYSTEMS

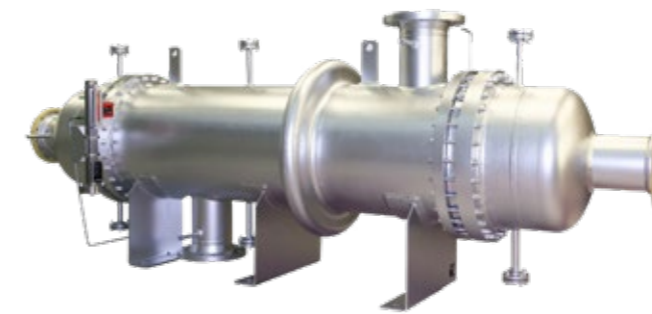

Heat exchanger function:	Oil Cooler (completely submersible in sea water)
Media tubeside	Sea water
Media shellside	Lubrication oil
Materials:	Carbon steel (coated where necessary), Copper, CuNi 90/10
Tube types:	Low-fin
Heat exchanger length:	900 mm
Heat exchanger diameter:	273 mm
Weight:	360 kg

A typical application is oil cooling in various stationary or mobile machines. One example is cooling the oil of an electric motor that drives the cutting head of a suction hopper dredger. The heat exchanger is fitted on the dredger arm, which means it is submerged in the sea during operation. For this application we provided our advanced model, manufactured with a thicker wall and coated with a special paint to make it resistant to sea water.

Heat exchanger function:	Water heater
Media tubeside	District heating water
Media shellside	Thermal oil
Materials:	Carbon steel
Tube types:	Plain
Heat exchanger length:	1900 mm
Heat exchanger diameter:	610 mm
Weight:	2335 kg

The heat from combined heat and power systems (CHP) can be fed into district heating systems. However, district heating systems are normally based on a water circuit, whereas the CHP cycle uses thermal oil, due its higher temperature. So an intermediate heat exchanger is needed. In the event of a leak the hot thermal oil could cause the water to evaporate, leading to serious damage. In this instance our advanced type, with fixed tube sheets and an expansion bellow, was the perfect solution for exchanging heat from the thermal oil to the water circuit.

Shell & Tube Double Safety – Customized

POLYSILICON PRODUCTION



Heat exchanger function:	Natural Chlorosilane mixture (partial) evaporator heated with steam
Media tubeside	Chlorosilane mixture
Media shellside	Water steam
Materials:	Carbon steel and stainless steel
Tube types:	Plain
Heat exchanger length:	7000 mm
Heat exchanger diameter:	1500 mm
Weight:	17.2 to

The corrosive nature of many media used in the chemical industry has made double tube safety heat exchangers the solution of choice for minimizing the risk of accidents and damage.

The production of polysilicon involves several chemical processes and cascades of heat exchangers and mostly hazardous materials are handled. Leakages in the course of polysilicon production cause unpredictable situations with regard to the workforce and the environment and to the process and the whole plant. Kelvion Shell & Tube Double Safety can help to prevent dangerous accidents, malfunctions and cost intensive downtimes in case of a leak.

One example in the polysilicon production is the utilization of our Shell & Tube Double Safety to evaporate chlorosilane mixtures in natural circulation by the use of condensing steam. Our fully customized types have been vertical positioned on support brackets.

Shell & Tube Double Safety – Customized

CHLORINE CONDENSER



Heat exchanger function:	Chlorine condenser using vaporizing ammonia
Media tubeside	Chlorine gas
Media shellside	Ammonia
Materials:	Carbon steel
Tube types:	Plain
Heat exchanger length:	4500 mm
Heat exchanger diameter:	500 mm
Weight:	2 to

A chlorine condenser is used to liquefy chlorine at the end of the chlorine production process to make it easy to store and transport. As chlorine is toxic and corrosive, double tube safety heat exchangers are the safe option. Chlorine is condensed on the tube side of the heat exchanger and ammonia evaporated on the shell side. The double tube design provides safety during a simultaneous phase change on both sides. In this way an intermediate circuit is unnecessary.



Shell & Tube Double Safety – Customized

NATURAL GAS TREATMENT

Kelvion's Shell & Tube Double Safety play an important role in the treatment of natural gas, including: gas pressure relief stations, underground storage and gas cooling. They are an essential part of combined cycle power plants for preheating gas before it enters the turbine for combustion. The main advantages for this application are high levels of safety, increased efficiency of the turbine, reduced gas consumption and lower emissions.



ADVANTAGES

- ▶ Higher safety with a simplified system
- ▶ Increasing of the turbine's efficiency
- ▶ Reduction of the gas consumption, lower CO₂ emission
- ▶ No immediate shutdown of the turbine after tube leakage
- ▶ Prevention of erosion damages of turbine buckets caused by higher hydrocarbons (retrograde condensation)
- ▶ Reduction / elimination of traditional cooling systems
- ▶ Savings in electrical auxiliary power and / or water consumption for cooling
- ▶ Available for most sizes of gas turbines
- ▶ Very short return of investment, high economical benefits

Heat exchanger function:	Performance Heater; heating of natural gas by feed water
Media tubeside	Natural gas
Media shellside	Feed water
Materials:	Carbon Steel
Tube types:	Plain
Heat exchanger length:	8.300 mm
Heat exchanger diameter:	500 mm
Weight:	9 to (skid)

OUR SERVICE IN THREE WORDS: PEACE OF MIND



START-UP SERVICES & ONSITE SERVICES

We ensure that our products are delivered safely and are fully validated to give a robust and reliable performance over as long a life cycle as possible.

And should you encounter a problem with your equipment after it is fully commissioned, our team of experienced Field Service technicians is at your disposal to come to your site to investigate and correct any malfunctions.

- ▶ Assistance to assembly and disassembly, shipping and transport



MONITORING, CONSULTING & TRAINING

Knowledge of the equipment's condition allows you to secure reliable production, improve safety and energy efficiency, increase equipment lifetime and prevent breakdowns. We offer consultancy services that take into account the special features of your process, making use of our profound design knowledge of heat exchange equipment. And we work closely with you to develop the exact solution that is best tailored to your needs.

- ▶ Function test of leakage switch and maintenance
- ▶ Thermal and hydraulic measurements at test stand (oil-water or water-water)
- ▶ Tightness test and refurbishment / repair
- ▶ Assessment of operating conditions
- ▶ Examination and assessment of operating conditions
 - ▶ Endoscopical examination of tube side regarding pollution, corrosion and erosion
 - ▶ Examination of shell side regarding pollution, corrosion and erosion
 - ▶ Analysis of water and other product samples
 - ▶ Investigation of corrosion problems (destructive testing and sample analysis with specialists)
 - ▶ Assessment of deposits or corrosion products which may possibly occur on the tube side
 - ▶ General visual inspection and documentation of results
 - ▶ Pressure test (tube and shell side)
 - ▶ Repeating pressure tests acc. to PED / DVGW (category I+II)
 - ▶ Repeating pressure tests acc. to PED / DVGW (category III+IV, Kelvion together with 3rd party)



SPARE PARTS AND SPARE PARTS SOLUTIONS

Even the best equipment shows signs of wear over time. We use only the highest quality spare parts, designed to match the excellence of the originals. This ensures that the optimum interaction between components is maintained. By safeguarding the original design, we offer maximum security of your investment.

- ▶ Delivery and assembly of spare parts



REPAIRS, OVERHAULS & MAINTENANCE

Unscheduled downtime can be disastrous. That is why our trained engineers are ready to respond quickly in case of an emergency, and review and repair components while keeping any disruption to your production to a minimum. Any overhaul work is carried out quality-oriented in our service centers or on your site with the supervision of our qualified staff. Regular inspections and maintenance help to reduce costs, extend the lifetime of your Kelvion products and achieve reliable performance.

- ▶ Complete overhaul, repair or new production
- ▶ Renewal of corrosion protection and exterior painting
- ▶ Internal cleaning (tube side: at factory or on site, shell side: at factory)
- ▶ Cleaning and flushing of shell and tube side including documentation of results
- ▶ Brush cleaning tube side including documentation of results (if screwed headers)



UPGRADES AND REPLACEMENTS

We replace components to keep our heat exchangers running smoothly and to prevent downtime. Where parts or components have become obsolete due to age, we will suggest a suitable upgrade. In these cases, we can often also suggest new, state-of-the-art technology which additionally enhances the performance and reliability of your process.

- ▶ Analysis and assessment of performance bottle-necks

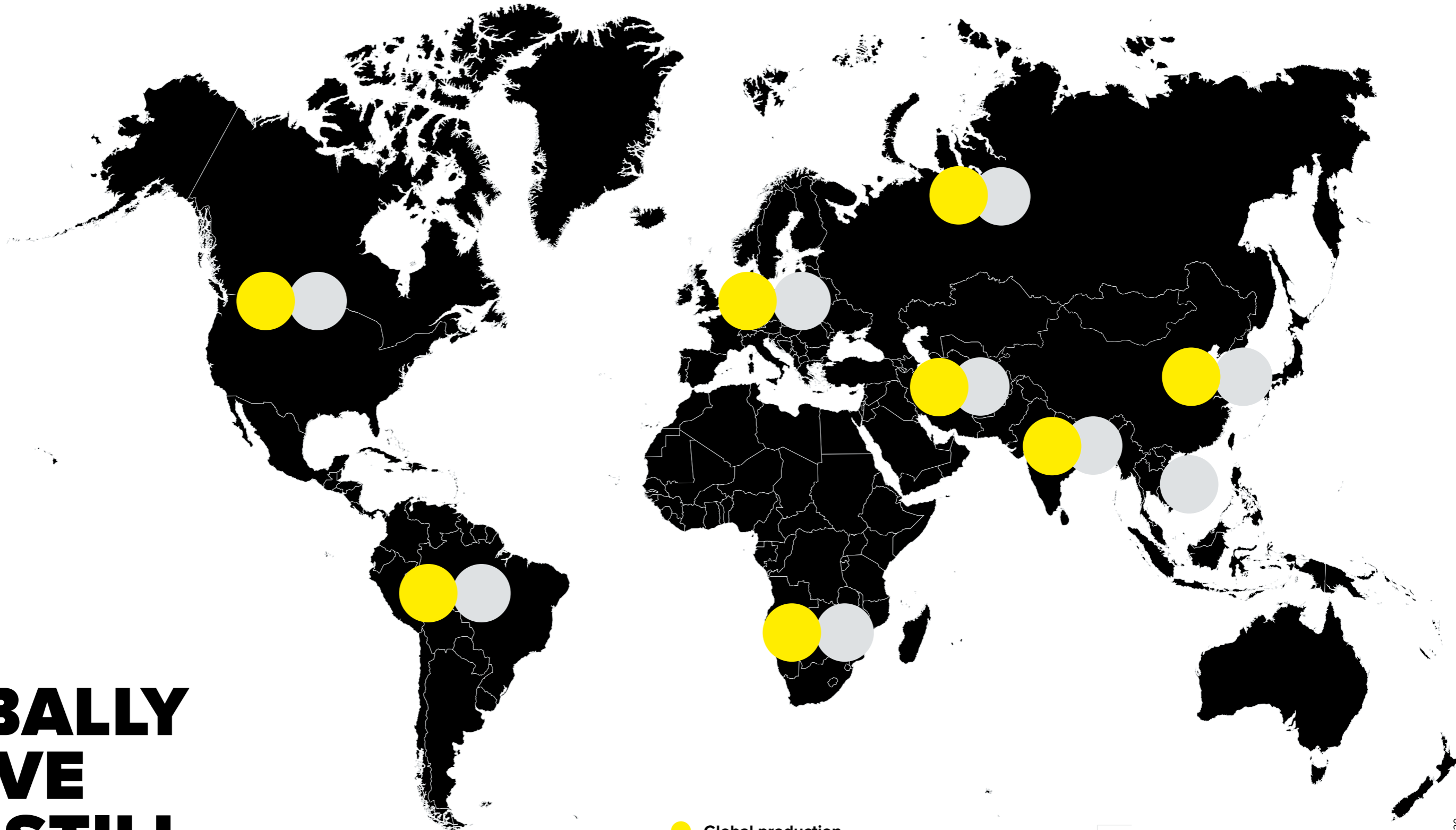

GLOBALLY ACTIVE AND STILL CLOSE BY

No matter where your market is, regardless of country, we are never far away. We are always happy to answer any questions you may have and meet your requirements. Even the largest, most successful project begins with an initial, profitable conversation. We look forward to hearing from you.

- Global production footprint
- Global sales and service



Just scan this QR code with your smartphone or visit our website at: www.kelvion.com – there you will find a highly competent contact in your immediate vicinity.

www.kelvion.com